

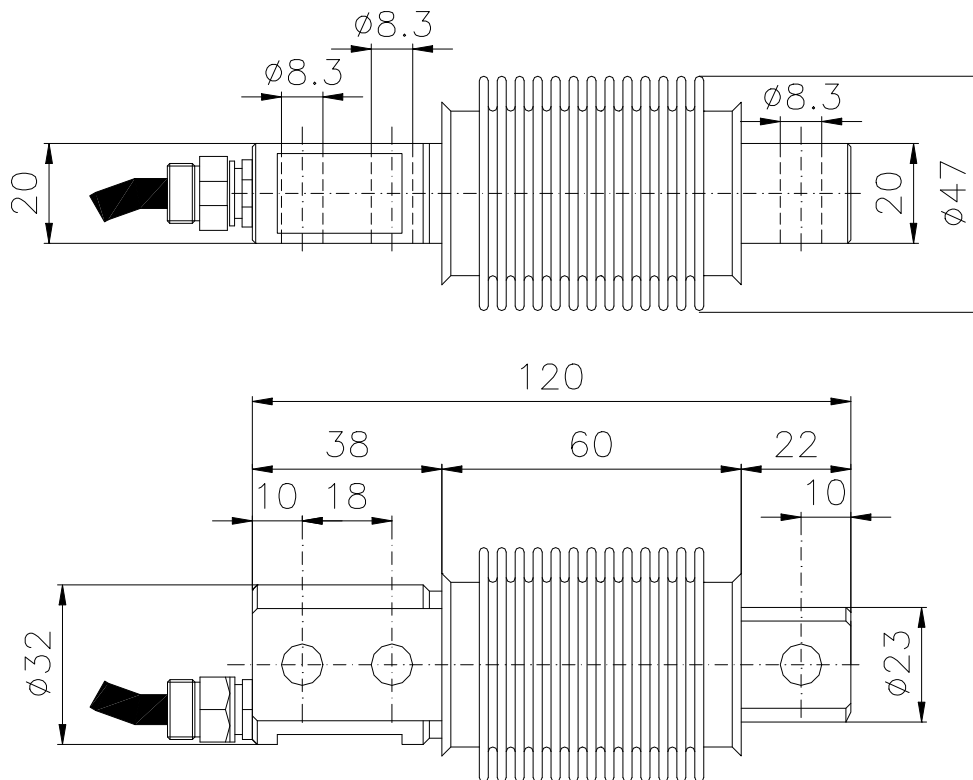

Capacity[Kg]	OIML
10	Yes
20	Yes
25	Yes
50	Yes
100	Yes
200	Yes

TECHNICAL CHARACTERISTICS	
Rated output	2 mV/V
Rated output tolerance	$\leq \pm 0,1\%$
Max excitation	15 Vcc
Zero balance	$\leq \pm 1\%$ f.s.
Input resistance	400 ± 20 ohm
Output resistance	350 ± 2 ohm
Insulation resistance	≥ 2000 Mohm
Combined error	$\leq \pm 0,025\%$ f.s.
Hysteresis	$\leq \pm 0,015\%$ f.s.
Creep 30'	$\leq \pm 0,024\%$ f.s.
Temperature effect on zero balance	$\leq \pm 0,005\%$ f.s./°C
Temperature effect on rated output	$\leq \pm 0,002\%$ f.s./°C
Compensated temperature range	$-10 \div +40$ °C
Operating temperature range	$-20 \div +70$ °C
Max safe load	150% f.s.
Bracking load	> 300% f.s.
Protection class	IP67
Material	Stainless steel
Standard cable length	5 m
OIML R60 C3/C4 version	On request



Wiring	
Red	+ Excitation
Blue	- Excitation
Yellow	+ Signal
Green	- Signal
White	+ Reference
Black	- Reference